

*Drawing restored from office records.  
Original lost or misplaced.*

*[Signature]*  
Clerk

3 Sheets—Sheet 1.

V. W. BLANCHARD.  
CARVING MACHINE.

No. 89,911.

Patented May 11, 1869.

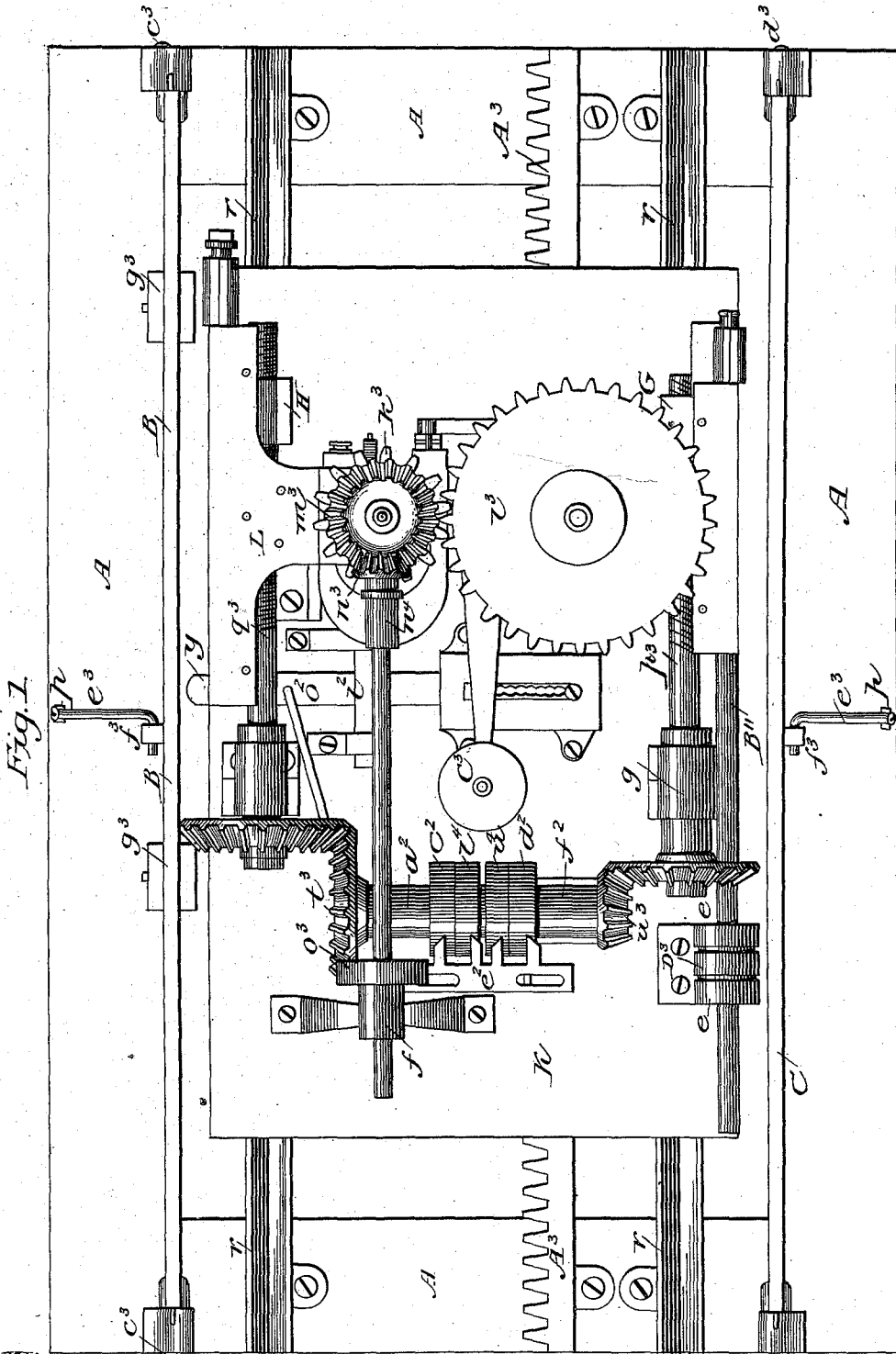

Fig. 1.

Witnesses:  
*[Signature]*  
*[Signature]*

Inventor:  
V. W. Blanchard  
By *[Signature]*, Atty.



Drawing restored from office records.  
Original lost or mislaid

*J. Smith*  
Clerk

3 Sheets—Sheet 3.

V. W. BLANCHARD.  
CARVING MACHINE.

No. 89,911.

Patented May 11, 1869.

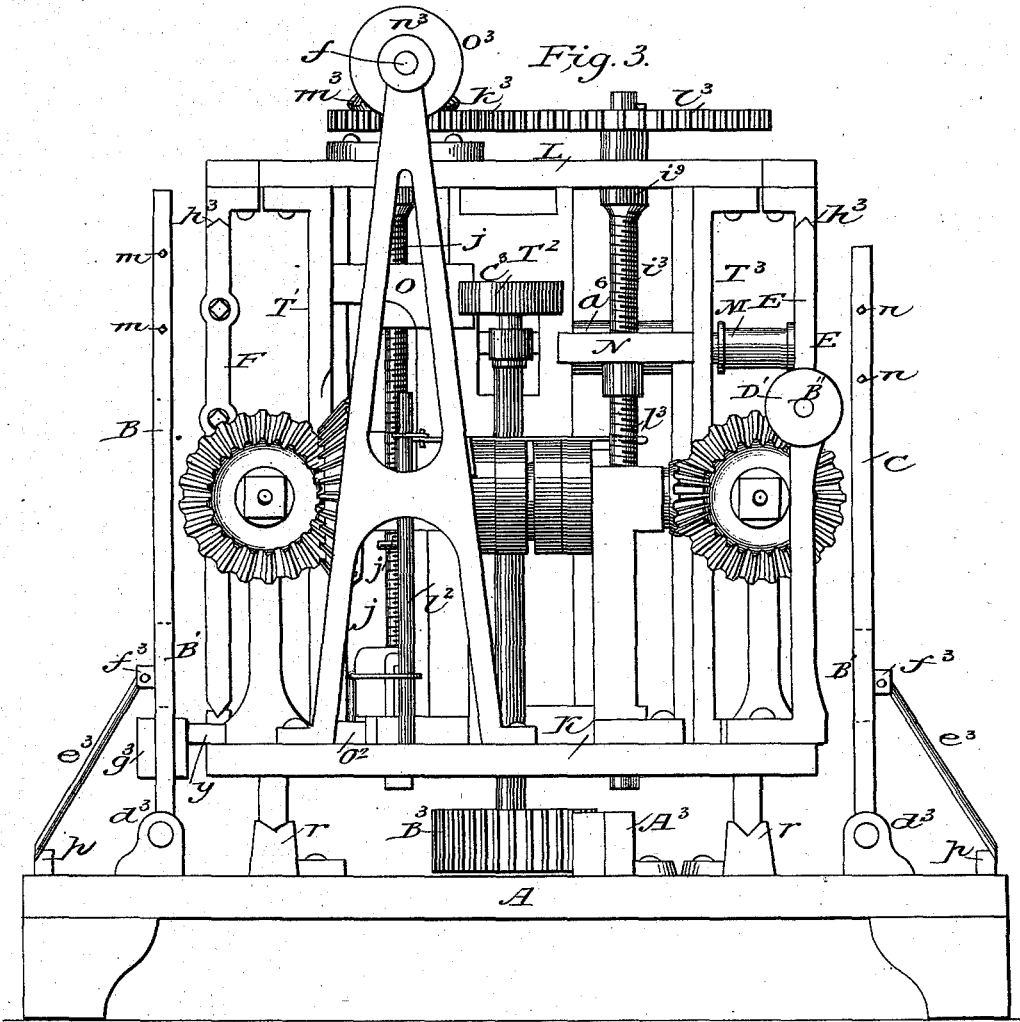

Witnesses:

*John Wells*  
*W. M. ...*

Inventor:

*V. W. Blanchard*

*J. W. Alexander*  
*Att'y*

# United States Patent Office.

VIRGIL W. BLANCHARD, OF BRIDPORT, VERMONT.

Letters Patent No. 89,911, dated May 11, 1869.

## IMPROVEMENT IN MACHINE FOR CARVING.

The Schedule referred to in these Letters Patent and making part of the same.

To all whom it may concern :

Be it known that I, VIRGIL W. BLANCHARD, of Bridport, in the county of Addison, and State of Vermont, have invented certain new and useful Improvements in Automatic Carving, Sculpturing, Engraving, and Polishing-Lathes, and Engines; and do hereby declare that the following is a full, clear, and exact description thereof, reference being had to the accompanying drawings, and to the letters of reference marked thereon, which form a part of this specification, and in which—

Figure 1 represents a plan view, Figures 2 and 3, end views of my sculpturing-machine.

Similar letters of reference indicate like parts in all the figures.

My invention consists in an improved engine, whereby wood, iron, stone, or any other suitable material may be carved, sculptured, channelled, or polished, as occasion may require.

My invention consists, further, in the employment of an improved mechanical device, whereby the superficial area of the pattern or copy may be, to any desired degree, greater than that contained in the work executed.

It also consists in the employment of a mechanical device, whereby the projection or depression above or below a plane surface, on the pattern or copy, may be made to any degree less than the corresponding ones produced therefrom on the surface of the work executed.

It also consists in the employment of several other devices, the peculiarity of which will be hereinafter fully specified.

To enable others skilled in the art to which my invention appertains, to make and use the same, I will now describe its construction and operation.

In the accompanying drawings—

A A represent bed-pieces, provided with ways, *r r*, the tooth-bar A<sup>3</sup>, and the folding frames B B and C C. K K represent a plate, resting upon and sliding on V, formed on its lower surface, on the ways *r r*, attached to the bed-pieces A A.

B<sup>3</sup> represents a toothed wheel, attached to a shaft, passing through the plate K K, and gearing with the tooth-bar A<sup>3</sup>.

C<sup>3</sup> represents a pulley, attached to the upper extremity of said shaft.

Motion is communicated to the pulley C<sup>3</sup>, through the shaft, to which it is attached, and the pinion B<sup>3</sup>, causes the plate K K to slide in either direction on the bed-pieces A A.

B B and C C represent the folding frames, attached, by hinges, *d<sup>3</sup> d<sup>3</sup>*, to the bed-pieces A A.

*e<sup>3</sup> e<sup>3</sup>* represent hinged stays, extending from the bed-pieces A A, at *p p*, to the cups in the studs *f<sup>3</sup> f<sup>3</sup>*.

By means of the hinged stays *e<sup>3</sup> e<sup>3</sup>*, the folding frames may be secured, in a vertical position, on the bed-pieces A A.

The spaces in the folding frames are divided longitudinally, into two apertures, by the central partition B<sup>1</sup> and C<sup>1</sup>.

The ends of the folding frames are provided, at their upper apertures, with set-screws, *m m m* and *n n n*.

In the upper or outer apertures of the folding frame B B, the copy of the design to be cut, carved, &c., is placed and secured by the screws *m m m*.

In the upper apertures of the folding frame C C, the material on which such design is wrought, is placed and secured by the set-screws *n n n*.

*g<sup>3</sup> g<sup>3</sup>* represent adjustable grooved stops, attached to the folding frame B B. These stops are provided with set-screws, by which they may be adjusted on the folding frame B B.

T<sup>1</sup> T<sup>2</sup> T<sup>3</sup> represent three upright posts, connected, below, with the sliding plate K K, and above, with the cross-pieces L L. These posts serve as guides to the nuts N and O, preventing the same from turning, and holding them firmly in a proper working-position.

The cross-pieces L L are provided with grooved ways, *h<sup>3</sup> h<sup>3</sup> h<sup>3</sup>*.

E and F represent two sliding frames, provided at their top and bottom with V-shaped surfaces, fitting and sliding in the ways *h<sup>3</sup> h<sup>3</sup> h<sup>3</sup>*.

*i<sup>3</sup> j<sup>3</sup>* represent two upright shafts, extending from the plate K K and cross-pieces L L. These shafts have bearings in the plate K K and cross-pieces L L, so that they will revolve freely in the same.

The shafts *i<sup>3</sup> j<sup>3</sup>* are cut, in their surface, so as to form screws; one a right-handed, and its fellow, a left-handed screw.

*k<sup>3</sup> l<sup>3</sup>* represent tooth-wheels, gearing into each other, and attached to the upper extremity of shafts *i<sup>3</sup> j<sup>3</sup>*.

*m<sup>3</sup>* represents a bevel-gear wheel, attached to the upper surface of the wheel *k<sup>3</sup>*, and gearing with the bevel-pinion *n<sup>3</sup>*, which communicates motion to a shaft, having one of its bearings, *f*, on the top of the stud rising from the plate K K, and the other, *n<sup>4</sup>*, on a projecting arm, attached to the cross-piece L.

O<sup>3</sup> represents a pulley, attached to the said shaft, near the bearing *f*.

O represents a nut, working on screw-shaft *j<sup>3</sup>*.

N represents a nut, working on the screw-shaft *i<sup>3</sup>*.

The sliding frames E and F are divided into two apertures, or openings, an upper and lower one.

G represents a nut, attached to the central bar or partition of the sliding frame E, and H a similar one, attached to the partition of the sliding frame F.

*p<sup>3</sup>* represents a screw-shaft, working in the nut G, and *q<sup>3</sup>*, a screw-shaft, working in the nut H. The screw-threads of the said shafts are cut in opposite directions.

*g<sup>1</sup>* represents a bearing, formed on the top of a stud rising from the plate K K, for the screw-shaft *p<sup>3</sup>*, and *d<sup>1</sup>*, a bearing, formed on the top of a stud, rising from the plate K K, for the screw-shaft *q<sup>3</sup>*.

*v<sup>3</sup>* represents a bevel-gear wheel, attached to the

shaft  $p^3$ , and  $s^3$ , a bevel-gear wheel, attached to the screw-shaft  $q^3$ .

$t^3$  represents a bevel-wheel gearing, with the bevel-gear wheel  $s^3$ , and  $w^3$ , a bevel-gear wheel, gearing with the bevel-gear wheel  $v^3$ .

$a^2$   $b^2$  represent bearings on the tops of two studs, rising from the plate K K, that sustain the shafts, to which the bevel-gear wheels  $t^3$  and  $w^3$  are attached.

$c^2$   $d^2$  represent two pulleys, attached to said shaft, and  $t^4$   $u^4$ , two loose pulleys, running on said shaft.

$e^2$  represents a belt-shifter, by means of which, two belts may be shifted, from the pulleys  $t^4$  and  $u^4$ , to the loose pulleys  $c^2$   $d^2$ .

By means of two belts, running in opposite directions, on pulleys  $t^4$ ,  $u^4$ ,  $c^2$ , and  $d^2$ , and the belt-shifter  $e^2$ , the shaft, on which the bevel-wheels  $t^3$   $w^3$ , are mounted, may be made to revolve in either direction, and, by the connections described, the sliding frames E and F may be made to move, simultaneously, in either direction, in their ways  $h^3$   $h^3$ .

$f^2$   $g^2$  represent two ratchet-wheels, attached to the upright screw-shaft  $j^3$ , and having their teeth cut in opposite directions.

$h^2$   $h^2$   $h^2$  represent four pawls, held in proper working-position, by springs, two of which act simultaneously on the ratchet-wheel  $f^2$  or  $g^2$ .

$i^2$  represents a sliding pawl-bar, to which said pawls are attached.

$j^2$  represents a connecting and disconnecting-lever, by which the upper and lower sets of pawls are connected and disconnected with the ratchet-wheels  $f^2$  and  $g^2$ .

$k^2$  is a movable shaft, provided with bearings, on the plate K K, and an arched bar, that connects the legs of the stud  $f$ .

$m^2$   $n^2$  are cranks, attached to shaft  $k^2$ .

$O^2$  represents a bar, that, by its connection, simultaneously actuating the pawl-bar  $i^2$  to a greater or less extent, and the belt-shifter  $e^2$  at such point in the movement of the sliding frame E, or the plate K K, as may be desired by the operator.

By means of a series of holes in the bar  $O^2$ , and an adjustable screw fitting the same, together with a slot in a plate, holding the said bar in a proper working-position, a variable movement may be communicated to the pawl-bar  $i^2$ .

$p^2$  is a stud, attached to the sliding frame E.

$\bar{P}$  is a rod, attached, by a pivot-joint, to the bar  $O^2$ , said rod passing through the stud  $p^2$ .

$q^2$   $q^2$  are two adjustable stops, provided with set-screws, and sliding on the rod  $\bar{P}$ , so, that when motion is communicated to the sliding frame E, the bar  $i^2$  and the belt-shifter  $e^2$  may both be actuated at any desired point.

By the connection, heretofore described, the action of the stud  $p^2$  on the adjustable stops  $q^2$  and  $q^2$ , or by the action of the bar  $O^2$ , at  $y$ , on the adjustable stops  $q^2$   $q^2$ , both the belt-shifter and the pawl-bar  $i^2$  may be actuated, at any desired point, in the movement of the sliding frame F, or of the plate K K.

$a^6$  represents a bearing, formed on the nut O, for the sliding shaft  $a^7$ .

$b^6$  is a bearing, formed in the top of a stud, rising from the nut O, for sliding shaft  $b^7$ .

$S^1$  is a bearing, formed in the lower end of stud, projecting downwards, from the nut O, for sliding arm S.

$a^7$  represents a shaft, sliding in the bearings  $a^6$  of the nut N.

M is a pulley, running on a bearing-surface, on the end of the sliding shaft  $a^7$ .

Pulley M is retained in its place by a set-screw entering a groove cut in the bearing-surface of the shaft  $a^7$ , and is provided with a cutting-point, of chisel, or a polishing-brush, composed of fine wire, or any other suitable material.

R is a nut, working on shaft  $a^7$ . By means of this nut, the sliding action of the shaft  $a^7$ , in its bearings,  $a^6$ , may be varied at pleasure.

Q is a lever, pivoted to the nut O, and connected, by a joint, with the shaft or arm  $b^7$ , and entering, by its other extremity, a notch, or mortise cut in one end of the sliding shaft S.

S is a shaft, sliding in its bearings  $S^1$ , and provided, near one end, with a notch or mortise, for the lower extremity of lever Q, and near its other extremity, with a recess or mortise, occupied by the sliding bar P. The bar P sliding in the recess near the extremity of the sliding shaft S, performs the function of connecting the mechanism with the nuts N and O, while a differential vertical action of said nuts takes place.

V represents a lever, pivoted, by one extremity, to the stud that projects downwards from the nut O, and, at its angle, to the extremity of the bar, that is pivoted, at its other extremity, to the shaft S.

By elevating and depressing the handle of lever V, the revolving cutting-point or polishing-brush is projected towards or withdrawn from the upper opening, in the sliding frame F, and, at the same time, the smooth end of the sliding shaft or arm, is likewise projected towards or withdrawn from the upper opening in the sliding frame E.

X represents a weight, connected, by a flexible connection, passing round the pulleys attached to the nuts O, to a pulley fixed on the lever Q, near its lower extremity.

The weight X, by actuating the lower arm of lever Q, serves to project the blunt end of the sliding shaft or arm  $a^7$  towards the upper opening in sliding frame E, and the cutting-point or polishing-brush, fixed in pulley M, towards the upper opening in the sliding frame E, and at the same time, to elevate the handle of lever V, which is provided with notches.

Y is a weight, provided with a hook, to fit the notches cut in the upper surface of lever V.

By shifting the weight Y to different notches in the handle of lever V, the weight X may be counterpoised at pleasure.

The sides of the upper opening, in the sliding frame C, are provided with set-screws  $m$   $m$   $m$ , by means of which the pattern of the design to be cut, &c., is secured in said frame.

The sides of the upper aperture, in the sliding frame B, are likewise provided with set-screws  $n$   $n$   $n$ , by means of which, the material on the cutting or polishing-point, fixed in the pulley M, is designed to act.

$a$  is an arm, forming a part of a secondary lathe, working in sliding frame E.

$B^7$  is the revolving shaft of said lathe, working in its bearings,  $b$ , and provided, at its extremity, with a notched chisel or edge, for holding fast the material fixed between it and the point of the adjustable arm  $a$ .

$e$  is a stud, rising from plate K K, and holding laterally, between its two arms, the pulley  $D^1$ , which is attached to the revolving sliding shaft B.

By the connections described, when the pulley  $D^1$  is connected, by a belt, with the pulley O, motion communicated to the revolving screw-shaft  $j^3$ , will cause the material to revolve, during the action of the sliding frame F, that may be engaged in its upper aperture, between the point of the lathe  $a$  and the notched edge or chisel, formed on one extremity of the revolving sliding shaft  $b^7$ .

In the practical operation of my machine, the pattern or copy of the design to be carved, &c., is secured in the upper opening of the sliding frame F by the set-screws  $n$   $n$   $n$ .

When it is desired to transfer the design of the pattern or copy to a plane surface in the material wrought, said material should be firmly secured in the upper opening of the sliding frame E by means of the set-screws  $m$   $m$   $m$ . If, however, it is desired to transfer

such design to a cylindrical surface in the material wrought, said material should be secured between the lathe  $a$  and  $b^6$  of the secondary lathe working in the upper portion of sliding frame E. In the first place, the spur-gear wheels  $h^3$   $b^3$  form a feed-communication between the shaft  $j^3$  and the shaft  $e^3$ , and the belt-connection between the pulleys  $O^3$  and  $D^1$  may be omitted. In the latter case, however, when the transfer of the design of the copy takes place to a cylindrical surface in the material wrought, the spur-gear wheel  $h^3$  should be removed from the shaft  $i^3$ , and motion should be transmitted from pulley  $O^3$  to pulley  $D^3$  by a belt or other similar means. By such connection, the feed-motion communicated to the shaft  $j^3$  will cause the material to revolve that may be engaged between the working-parts of the secondary lathe in the upper portion of sliding frame F. In the latter instance, just described, as the nut N will remain stationary on the shaft  $i^3$ , it will be necessary to adjust said nut on said shaft so that the centre of the cutting-point or polishing-brush of the pulley M will occupy a working-position opposite to or in the same plane with the centre of the working-parts of the secondary lathe in the upper opening of the sliding frame F.

When the copy and the material to be wrought are properly secured, as described, and the mechanism adapted to the nature of the work to be done, and the nut O raised to such a position on shaft  $j^3$  that the blunt extremity of the sliding arm or shaft  $b^7$  is pressed against the upper margin of the copy by the weight X acting through the lever Q over the handle of the connecting and disconnecting-lever  $j^2$ , it should be actuated so as to connect, in a proper working-relation, the lower set of pawls attached to the pawl-bar  $i^2$  with the ratchet-wheel  $f^2$ . At this point, the adjustable stops  $q^2$   $q^2$  on rod  $l^1$  should be secured to said rod, on which they, by means of their set-screws, give the sliding frames E and F the required amount of sliding motion. Also, by means of the nut R on the shaft  $i^2$ , the cutting-point of the chisel or tool fixed in the pulley M should be allowed to project toward the material to be wrought, that has been secured, as described, in the sliding frame F as far as it may be deemed proper to make the impression.

By the application of motive-power, through belts, as described, to the pulley M, bearing the cutting-point of the machine, and also to the pulley  $d^2$  and loose pulley  $u^4$ , the chisel or cutting-point fixed in the pulley  $m$  is caused to revolve, and, through the shaft to which the pulley  $d^2$  is attached, and bevel-wheels  $t^3$  and  $u^3$ , motion is communicated through the bevel-gear wheels  $r^3$  and  $s^3$  to the screw-shafts  $p^3$  and  $q^3$ .

Motion communicated to the screw-shafts  $p^3$  and  $q^3$ , through the nuts H and G, will cause a sliding motion to take place in the frames E and F. The sliding motion just described, of the frames E and F, will continue in one direction until the stud  $p^2$ , actuating the rod  $l^1$  by means of one of its adjustable stops  $q^2$ , causes, by means of connections that have been described, such an action of the belt-shifter  $e^2$  as to shift the belt running on the loose pulley  $u^4$  to the pulley  $e^2$ , and the belt running on the pulley  $d^2$  to the loose pulley  $t^4$ . As the belt running on the pulley  $e^2$  runs in an opposite direction to its fellow, it is obvious that the sliding motion of the frames E and F will, by the action of the belt-shifter  $e^2$ , be reversed, and that this reversed motion of the sliding frames E and F will be continued until the stud  $p^2$ , by means of the adjustable stop  $q^2$  and rod  $l^1$ , returns the belt-shifter  $e^2$  to its original position.

When it is desired to adapt the machine to work on extensive surfaces, the pattern or copy should be secured in the upper opening of the folding frames B B by its set screws  $n n n$ , and the material to be wrought should likewise be secured in the upper opening of the folding frame C C by the set-screws  $m m m$ .

The mechanism forming the secondary lathe, and shown combined with the sliding frame F, may be combined as described with the folding frame C C. In such case the stud  $e$ , that is shown mounted near the rear margin of the plate K K, would require a hinged or folding attachment to the same, and it would be necessary to prolong the rear portion of the plate K K to a greater or less extent to furnish such support and attachment. In this case, the studs  $e$  and pulley  $D^1$  would be mounted sufficiently in the rear of and in a line with the folding frame C C to allow the action of the sliding plate K K to take place on the bed-piece A A, and the studs  $e$  and pulley  $D^1$  would require to be in the rear of sliding plate, as now shown, a distance equal to the action of said plate on bed-piece A A. In such case, the revolving shaft  $B^7$ , feathered to the pulley  $D^1$ , would slide in the bearings of the hinged studs mounted on a prolongation of the plate K K, as described, during the action of the said plate on its bed-piece A A.

The adjustment of the adjustable stops  $g^3$   $g^3$ , which actuate the extremity of the bar  $o^2$  at  $y$ , during the sliding motion of the plate K K on the bed-piece A A, forms the connection of said bar with the belt-shifter  $o^2$ , as described. When the shaft on which the pulleys  $u^4$ ,  $d^2$ , and  $t^4$  are mounted is connected, by some suitable means of transmitting motion, with the pulley  $e^2$ , and motion communicated to the pulleys  $u^4$ ,  $d^2$ , and  $t^4$  in the same manner as has been described in the case of the sliding frames E and F, it is evident that a backward and forward sliding action is produced in the plate K K.

By shifting the position of the adjustable stops  $g^3$   $g^3$ , a greater or less sliding action of the plate K K may be produced.

When the folding frames B B and C C are used instead of the sliding frames E and F, a greater length in the arm  $b^7$  and the cutting-point and polishing-brush will be required.

In the use of either the folding frames B B and C C or the sliding frames E and F, at the same time, the bar receives, by connections described, an impulse from the contact of the stud  $q^2$  with the adjustable stops,  $g^3$   $g^3$ , and motion is communicated from the pawl-bar  $d^1$ , by its lower set of pawls, to the ratchet-wheel  $f^2$ . Motion thus communicated causes the nuts O and N to fall on the shafts  $i^3$  and  $j^3$ , on which they work, carrying with them the arm  $b^7$  and the cutting-point or polishing-brush inserted in pulley M.

By use of the different gear-wheels  $t^3$  and  $u^3$ , which are attached to the shafts  $p^3$  and  $q^3$ , in combination with the use of the differential bevel-gear wheels  $i^3$  and  $j^3$ , the vertical action of the nut O on the shaft  $j^3$  is double that of the action of the nut N on the screw-shaft  $i^3$ , and the lateral action of the nut O on the screw-shaft  $j^3$  is double that of the lateral action of the nut H on the screw-shaft  $p^3$ . By this means, the pattern or copy will contain four times the superficial area, contained in the material wrought, that is secured in the upper opening of the sliding frame F or folding frame C C.

By means of the sliding bar P, the differential motion of the nuts N and O takes place without disturbing the working of the mechanism that connects them. Thus, by varying the size of the gear-wheels  $t^3$  and  $u^3$ , and the bevel-gear wheels  $p^3$  and  $q^3$ , I am able to multiply to any degree the superficial area contained in the object carved, &c., in that contained in the pattern or copy from which the same is produced, by being able to increase the area of the pattern or copy to any desired degree, and at the same time to diminish the projections and depressions on its surface to any desired extent.

For engraving-purposes, the long arm of lever Q will be required above its fulcrum, and its short arm below.

By the mechanism described, a compound action is experienced, in the cutting or polishing-points, by the material secured in the sliding frame F or folding frame C O; a planing action from the sliding motion of the frame F or plate K K; a revolving action from the cutting-point or polishing-brush fixed in the pulley M; and a revolving action from the material itself, derived from the revolving shaft.

Having thus described my invention,

What I claim as new, and desire to secure by Letters Patent, is—

1. The employment of the nuts G and H, screw-shafts  $p^3$  and  $q^3$ , in combination with the two upright screw-shafts  $i^3$  and  $j^3$ , and nuts N and O, for the purpose of giving at the same time a longitudinal-sliding motion to the pattern or copy, and the material furnished to be carved, &c., and a rising and falling vertical motion to the moulding and cutting or polishing-points of the lathe or engine, substantially as and in the manner set forth.
2. The employment of the sliding frames E and F, and nuts H and G attached to said frames, in combination with the screw-shafts  $p^3$  and  $q^3$ , having the mechanism for communicating motion to said shafts, substantially as and for the purpose described.
3. The nuts N and O, in combination with the screw-shafts  $i^3$  and  $j^3$ , and guides T<sup>1</sup>, T<sup>2</sup>, and T<sup>3</sup>, as and for the purpose set forth.
4. The shaft  $a^7$ , carried in the nut N, with the nut R and arm P, arranged and operating substantially in the manner and for the purpose specified.
5. The arm  $b^7$ , lever Q, and shaft S, carried by the nut O, arranged to operate substantially as described.
6. The combination of the shaft  $a^7$ , carried in the nut N, nut R, and arm P, with the arm  $b^7$ , lever Q, and shaft S, substantially as described.

7. The weighted lever V, pivoted to the arm of nut O and the sliding frame S<sup>1</sup>, in combination with shaft S, arranged to operate substantially as described.

8. The weight X, in combination with the lever Q, arm  $b^7$ , nut O, and screw-shaft  $j^3$ , arranged to operate substantially as and for the purpose set forth.

9. The employment of the lathe-mechanism attached to sliding frame E, consisting of the parts  $a$  and  $B''$ , in combination with said frame, substantially as described.

10. The employment of the mechanism mounted on the sliding plate K K, in combination with the bed-plate A A, ways  $r r$ , tooth-bar A<sup>3</sup>, and folding frames B B, when all the parts are constructed and arranged to operate substantially as and for the purpose described.

11. The ratchet-wheel  $f^2$ , pawl  $h^2$ , disconnecting-lever  $c^5$ , and the shaft  $j^3$ , arranged and operated substantially as set forth.

12. The adjustable feed-mechanism, consisting of feed-bar O<sup>2</sup>, the plate above it provided with a slot or mortise, and a screw, to vary the length of the stroke, substantially as and for the purpose set forth.

13. The arrangement of the differential gear-wheels,  $k^2$ ,  $b^2$ ,  $t^2$ , and  $u^2$ , with the screw-shafts  $i^3$ ,  $j^3$ ,  $p^3$ , and  $q^3$ , and nuts N, O, H, and G, substantially as and for the purpose set forth.

In testimony that I claim the above as my own, I hereby affix my signature, in the presence of two witnesses.

VIRGIL W. BLANCHARD.

Witnesses:

N. S. BENNETT,  
C. W. EARL.